

ICS

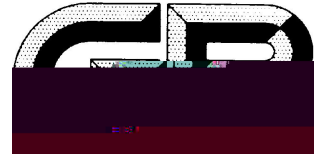

GB/T



中华人民共和国国家质量监督检验检疫总局 发布
中国国家标准化管理委员会

SAC/TC285

GB /T 2542
GB /T 12988
GB/T 25183
GB/T 26001
GB 28635
GB 50763

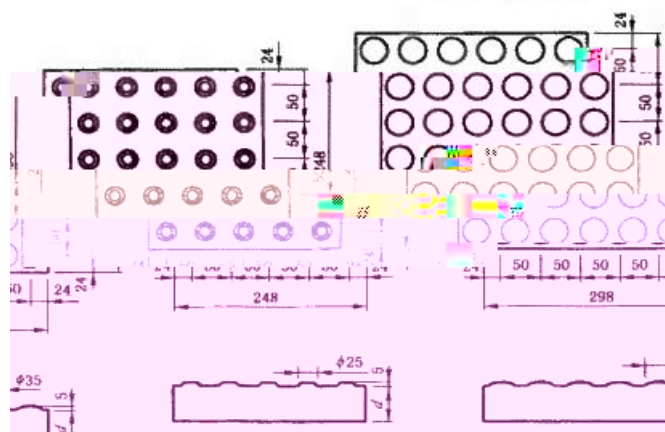
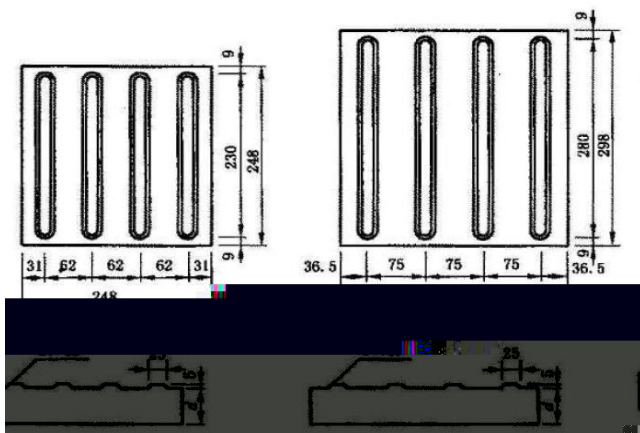

	5
	25
	35
	35
	62 75
	31 36.5

	5
	25
	35
	50
	24

	148 198 248 298
	50 60

4

		5
		1
		10
		1
		10

5

1		+2.0 0.0
2	/	1.0
3	/	1.0
4	/	1.0
5		1.0

	2.0

	2.0
	2.0

M			M			(%)
C 40	40.0	35.0	C 4.0	4.00	3.20	6.5
C 50	50.0	42.0	C 5.0	5.00	4.20	
C 60	60.0	50.0	C 6.0	6.00	5.00	

M			(%)
C 35	35.0	29.0	12.0
C 45	45.0	38.0	10.0
C 55	55.0	49.0	8.0

1		32.0
2	BPN	60
3	D50	5
	D35 D25	% 20.0
4	/ ²	1000 1500

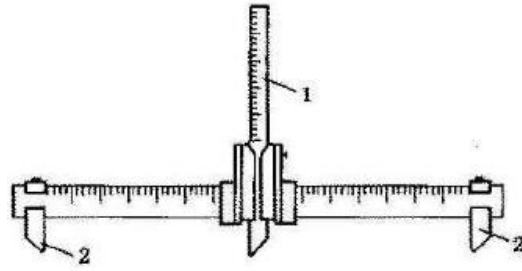

1

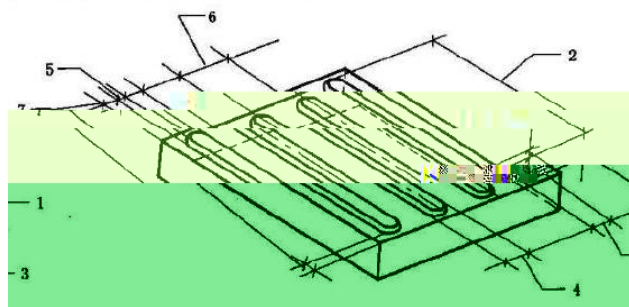

1

2

3

4

5

6

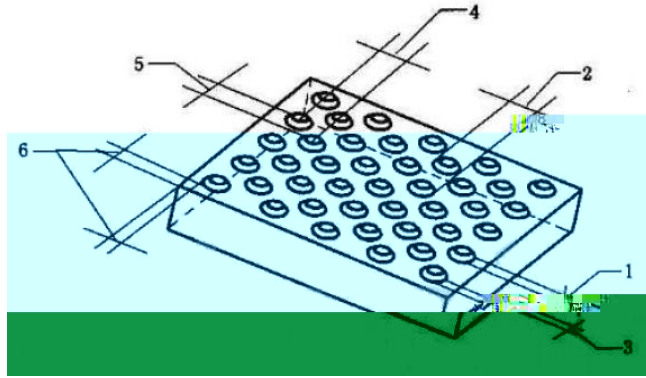

- 1
- 2
- 3
- 4
- 5

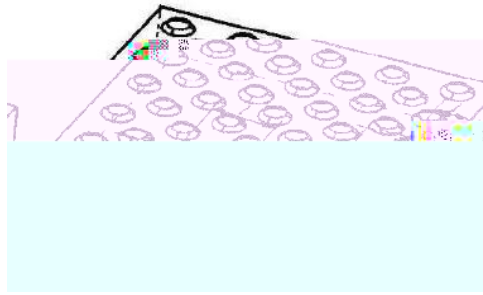

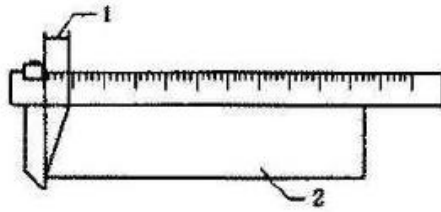
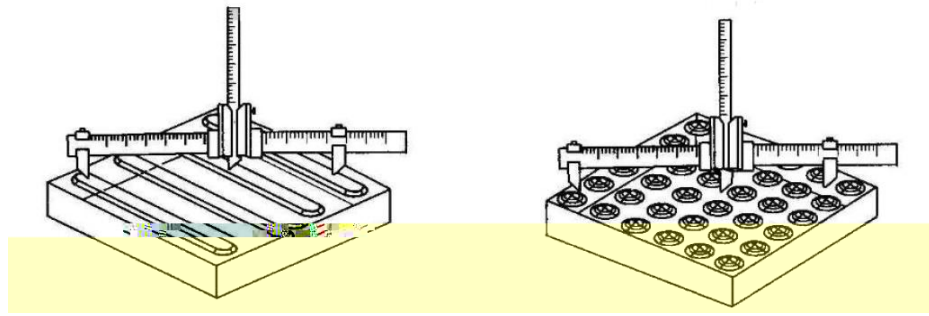

$$K_R = \frac{f_f - f_R}{f_f} \times 100$$

1		50 1= 2=50
2		10
		20
3		10
4		5
5		5
6		5
7		10
8		5
9		5

K₁ 3

K₁ 7

4 K₁ 6

